

Approved as per  
 No. 417 dt: 25.9.96.

A/2402/1606/96.  
 Planning Permit No. \_\_\_\_\_  
**APPROVED**  
 SUBJECT TO THE CONDITIONS IN  
 THIS OFFICE LETTER.  
 No. A2/2397/196 Date 12-9-96  
 FOR MEMBER SECRETARY  
 MADRAS METROPOLITAN  
 DEVELOPMENT AUTHORITY  
 MADRAS - 600 008.

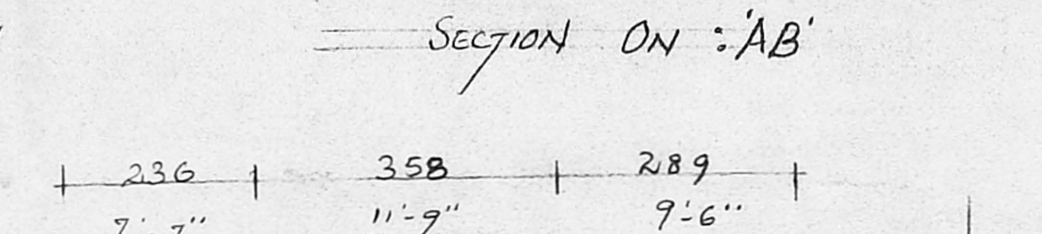

- SPECIFICATIONS**
- SAND FILLING IN FOUNDATION
  - FOUNDATION CONCRETE IN C.M 1:5:10
  - SAND FILLING IN BASEMENT
  - PUNTH BEAM IN C.M 1:2:4
  - BRICK WORK IN C.M 1:6
  - R.C.C. LINTELS IN C.M 1:2:4
  - R.C.C. SUNSHADE IN C.M 1:2:4
  - R.C.C. ROOF SLAB IN C.M 1:2:4
  - EXISTING MADRAS TERRACE ROOF
  - EXISTING A.C. SHEET ROOF TO BE REMOVED
  - DRAPEY WALL IN C.M
  - WEATHERING COURSE LAID TO SLOPE
  - CELLING PLASTERING IN C.M 1:3
  - WALL PLASTERING IN C.M 1:6
  - FLOORING CONCRETE IN C.M 1:4:8
  - MOSAIC FLOORING IN C.M
  - WHITE WASHING
  - COLOUR WASHING

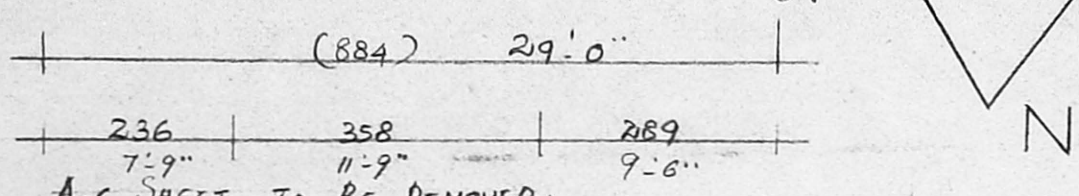
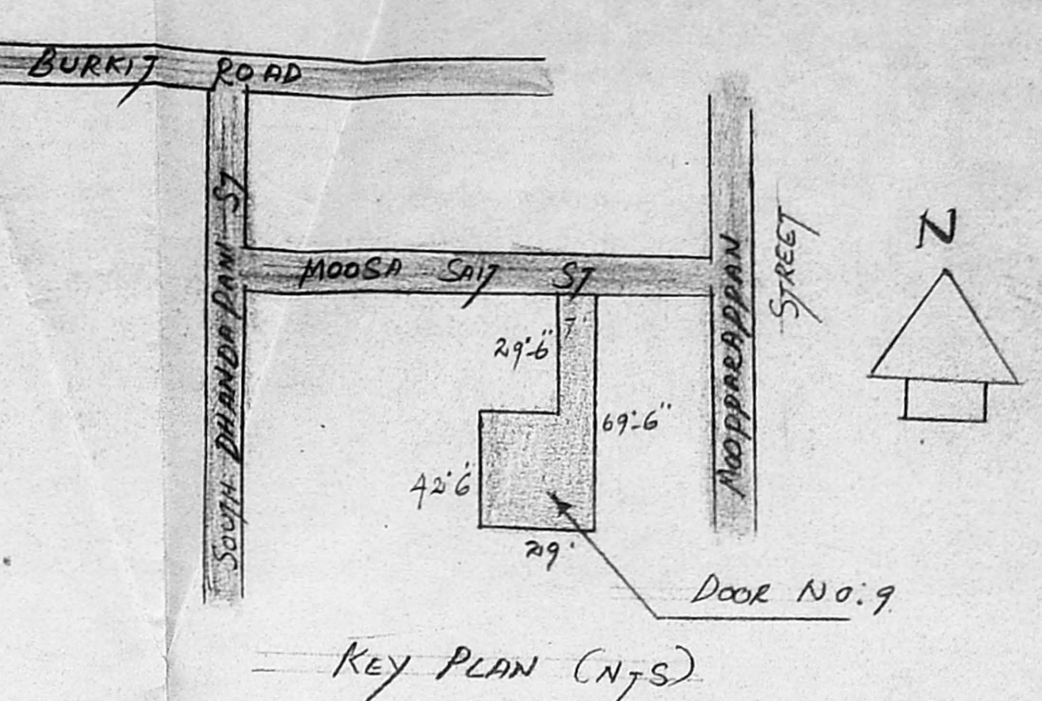
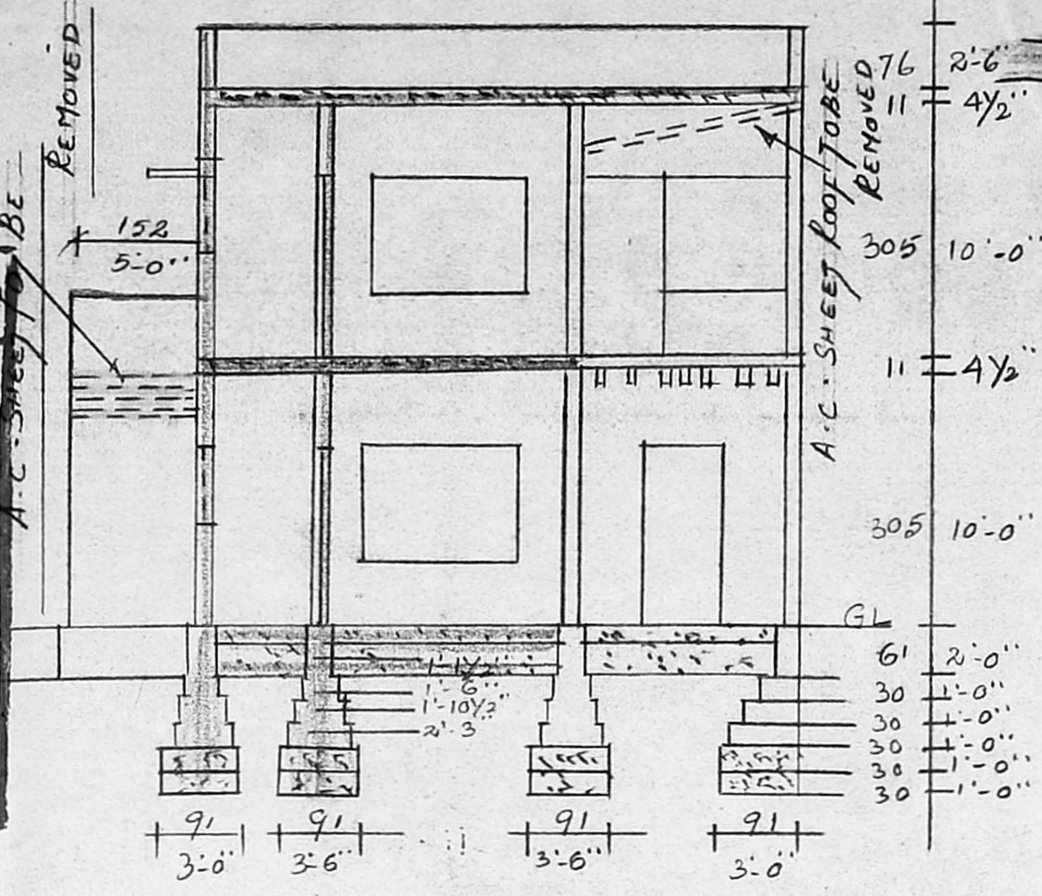
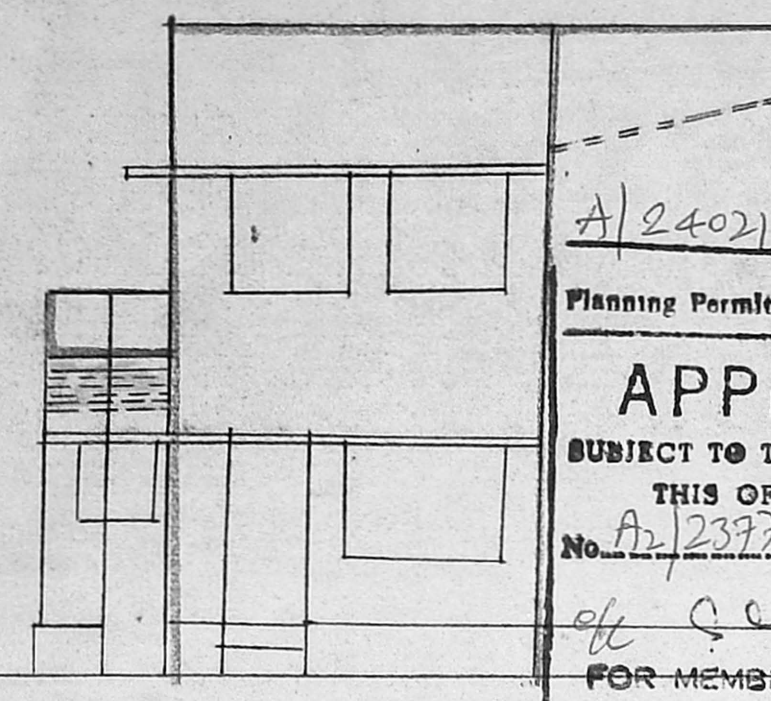
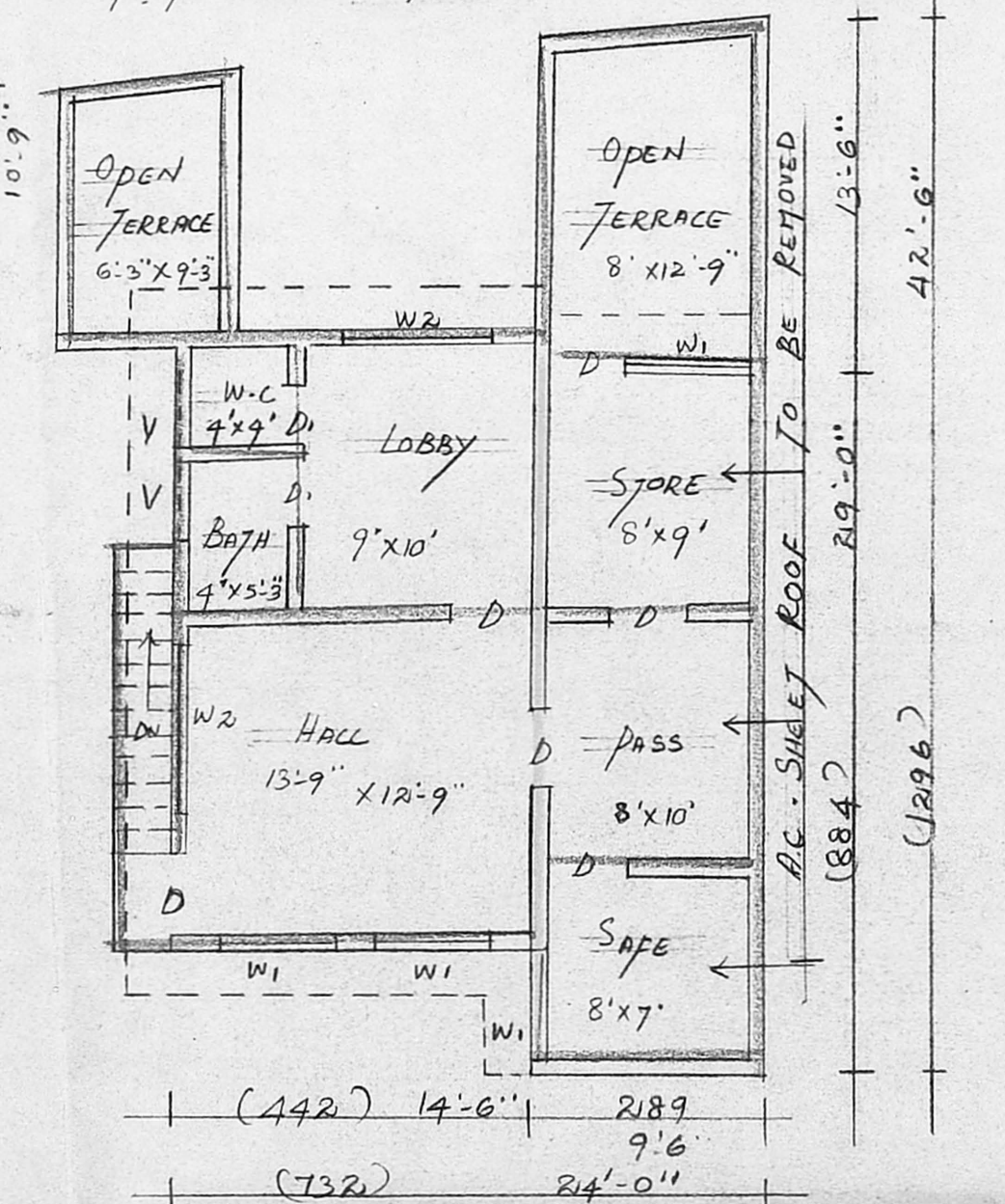
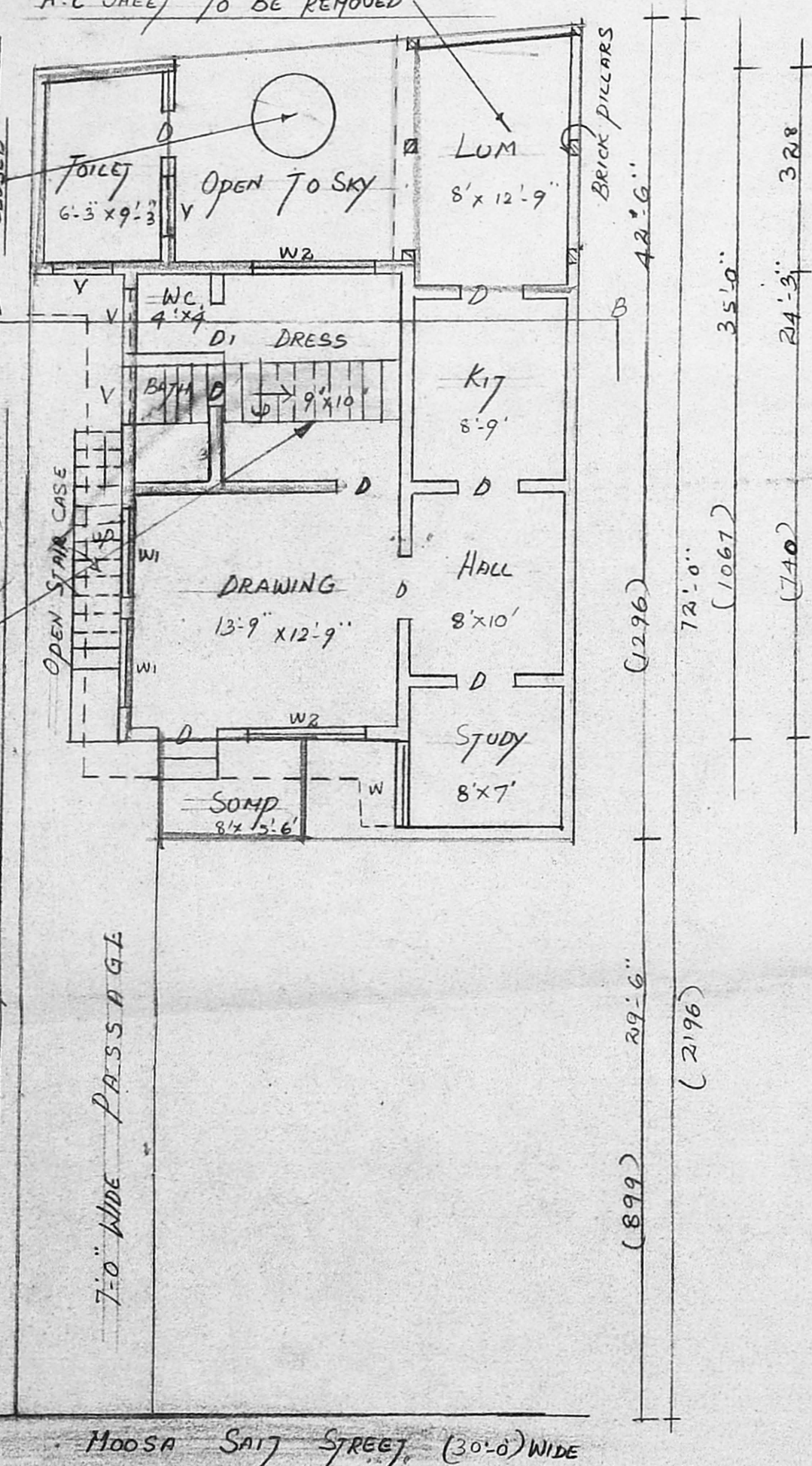

**JOINERY DETAILS**

D - DOOR	91 X 213	3'-0" X 7'-0"
Di - DOOR	76 X 213	2'-6" X 7'-0"
W - WINDOW	130 X 137	4'-3" X 4'-6"
W1 - WINDOW	137 X 137	4'-6" X 4'-6"
W2 - WINDOW	183 X 137	6'-0" X 4'-6"
V - VENTILATOR	91 X 91	3'-0" X 3'-0"

**COLOUR REFERENCE**

EXISTING	[Line]
PROPOSAL	[Line]
ROADS	[Line]
PLOT BOUNDARY	[Line]
TO BE REMOVED	[Line]

FIRST FLOOR PLAN

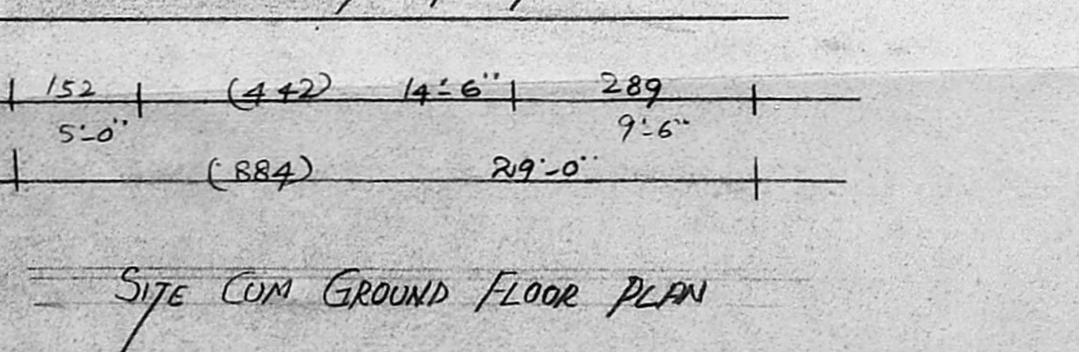
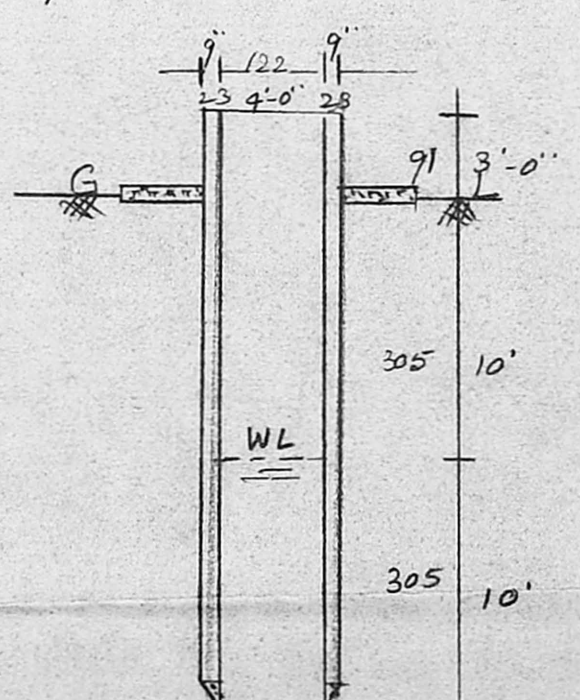

PLAN SHOWING THE PROPOSED ADDITIONS AND ALTERATIONS IN THE EXISTING BUILDING AT DOOR NO: 9 OF MOOSA SAIB STREET, BEARING R.S.NO. 139/5, 7.S.NO. 9149, BLOCK NO. 131 OF 7-NAGAR REVENUE VILLAGE, 7-NAGAR, MADRAS - 600017, IN CORPORATION DIVISION 140. SCALE - 1:100

M. S. RAJESWARA CHARYULU,  
 L.C.E., A.I.D., Grad I, Street E.,  
 Architect Engineer & Contractor,  
 Panel Valuer/Insurance Surveyor & Loss Assessor Govt. of India,  
 Panel Engineer / H.R.C.E. Govt. of Tamilnadu,  
 Licensed Surveyor Corporation of Madras,  
 Ambattur & Avadi Real Estate Promoter,  
 Res: 33/6, Ramaswamy St., Off: 49, Ramaswamy Rd.,  
 T. Nagar, Madras-17, T. Nagar, Madras-17.